



PCS
PROTOTYPE & CASTING SOLUTIONS

PROTOTYPES • CASTINGS • PROJECTS • CORESHOP • TOOLS

ABOUT OUR COMPANY



We are specialized in the supply of prototype castings in aluminium, steel, grey, and ductile iron. Within our **PROTOTYPE&CASTING SOLUTIONS TEAM** we will select the right partner for your casting and machining needs. Our group of experienced professionals is dedicated to providing the highest quality products and services from project to the end product *in one place*. We can also help you develop foundry tools, construct machines for core production, and optimize your core production process.

WHAT WE OFFER

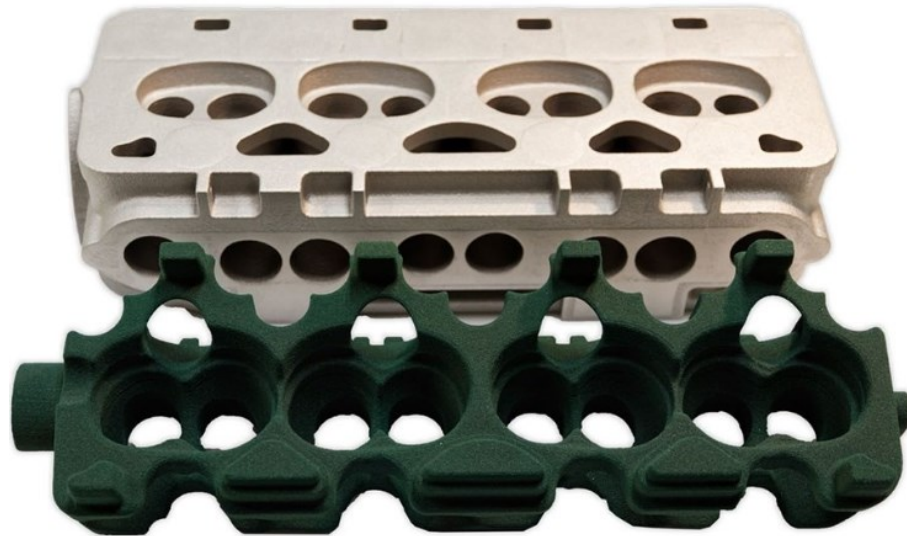

- 2D and 3D modeling, reverse engineering
- Foundry tools manufacture
- Production of prototype castings from aluminum, grey iron, ductile iron, and steel using binder jetting or traditional methods
- Grinding, sandblasting, coating, machining and measuring/control procedures
- Consulting services for the optimization of core production
- Core shooting machines for foundries

RAPID PROTOTYPING PROCESS

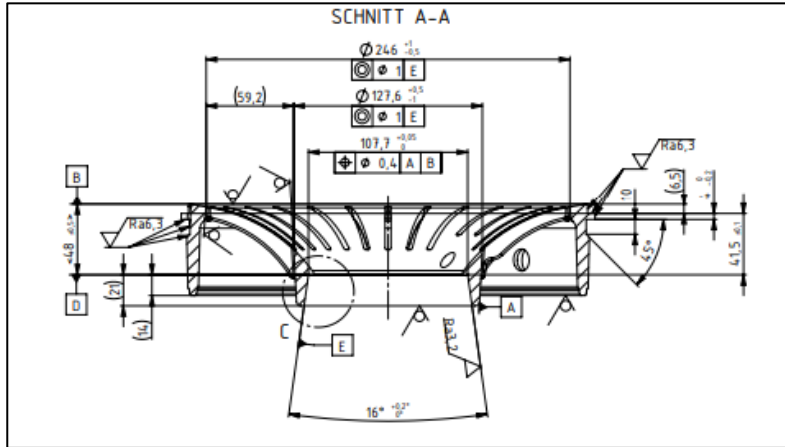

2D Design



3D printed sand moulds and cores production by binder jetting

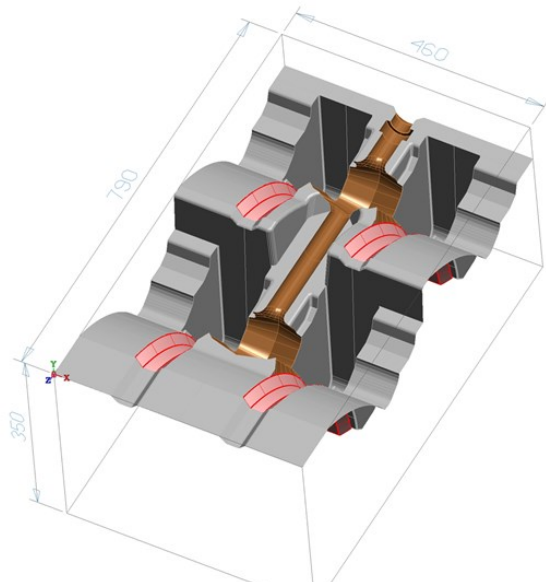

3D Design

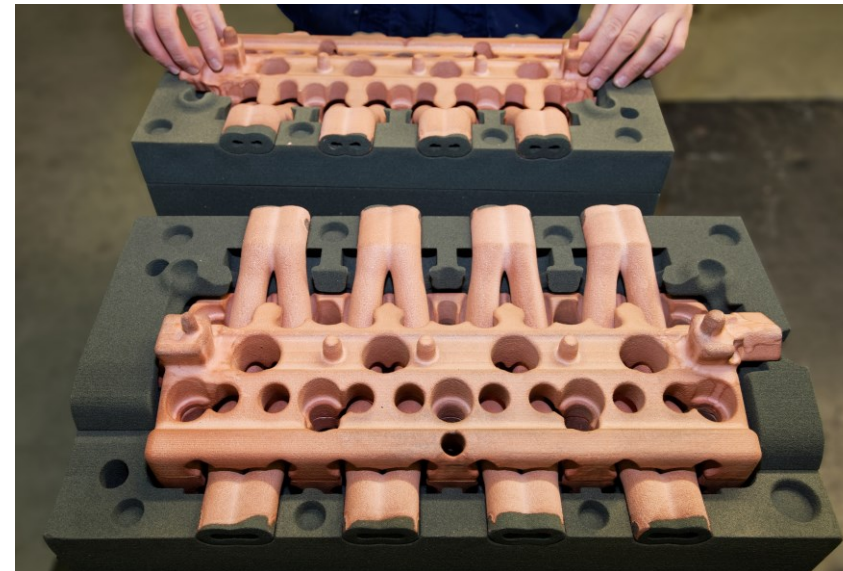

3D printed sand moulds and cores assembly

Providing a complete service from design to functional end product

RAPID PROTOTYPING PROCESS



Moulds and cores assembled and ready for casting



Raw castings



Metal pouring

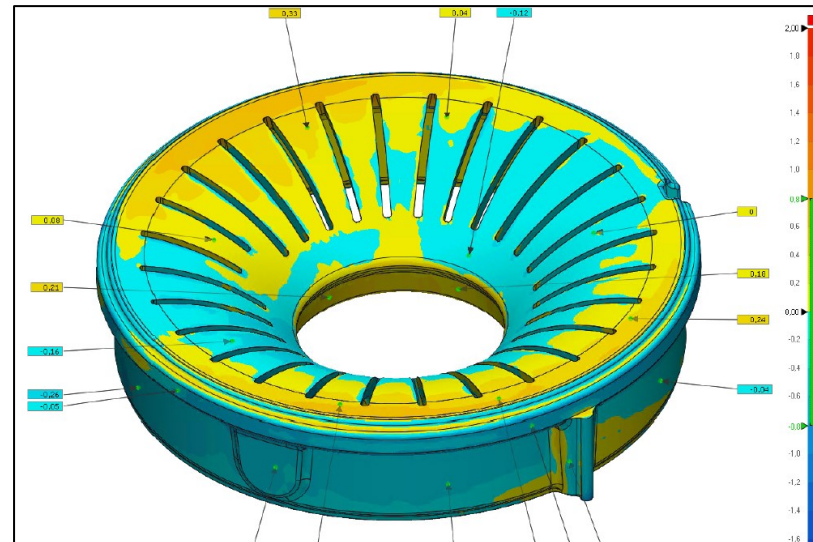

3D scan and comparison between 3D design and raw casting

RAPID PROTOTYPING PROCESS



Machining

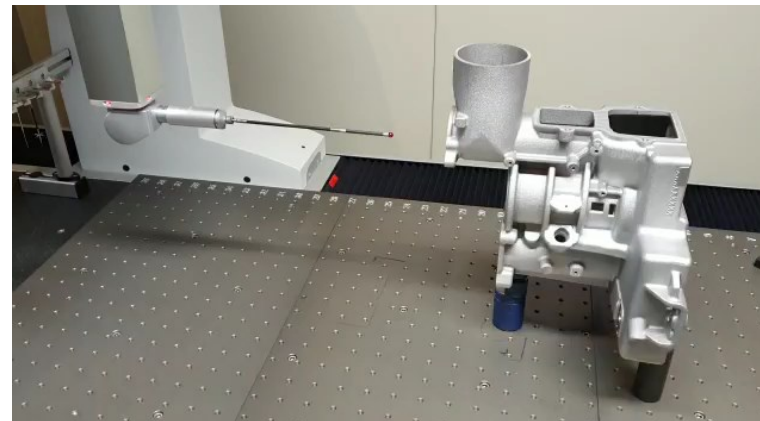

Dimensional control of the machined area



Quality control and identification

Providing a complete service from design to functional end product

TOOL PRODUCTION



Production of highly elaborate metal and resin patterns for earth moving, agriculture, energy, railway and automotive sector.

- tools for cylinder blocks, cylinder heads, axle housing, gear cases, differential gears
- tools for the manufacture of composite products
- tools for thermoforming and plastic injection
- tools for aluminium casting by gravity, low and high pressure die casting

MACHINE PARK:

- High-speed 3, 4 and 5-axis milling machines (working range up to 4500 x 2500 x 1250 mm)
- EDM wire cut machines

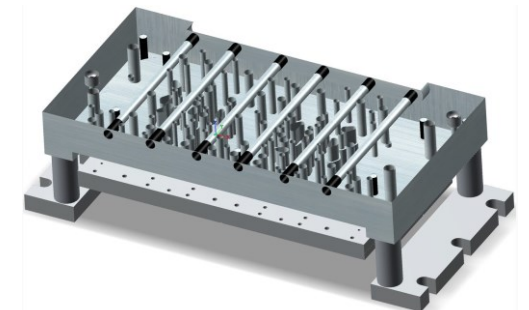

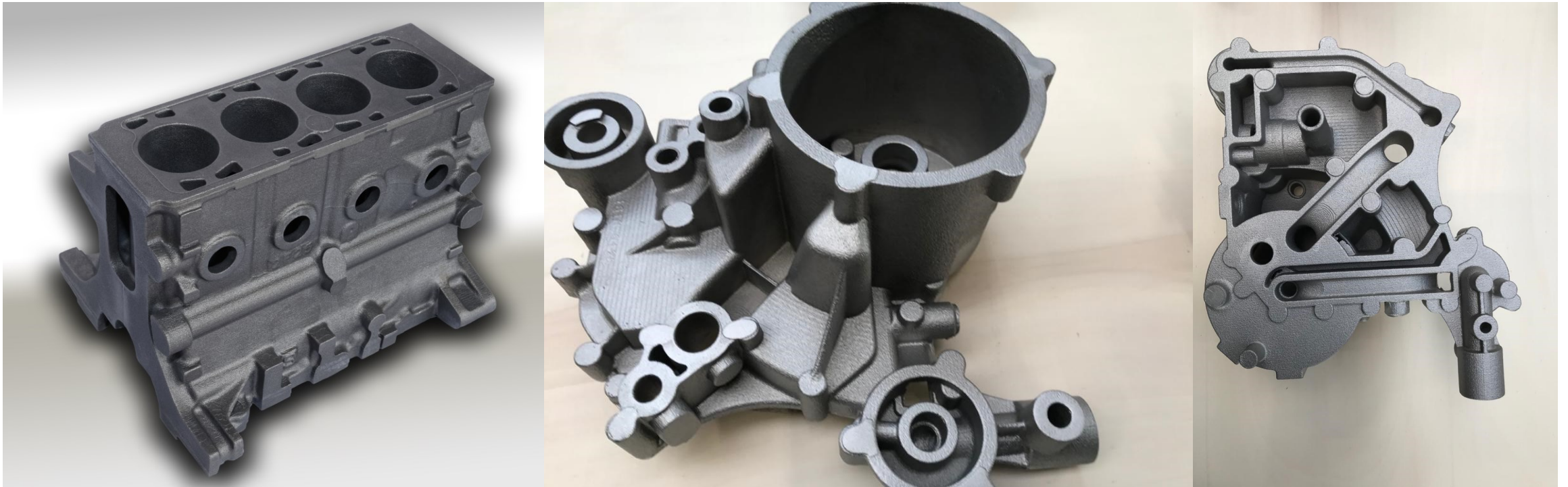

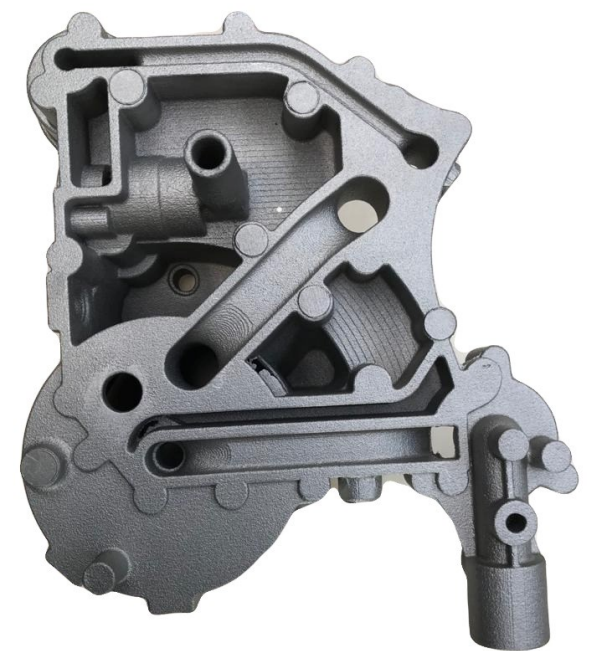
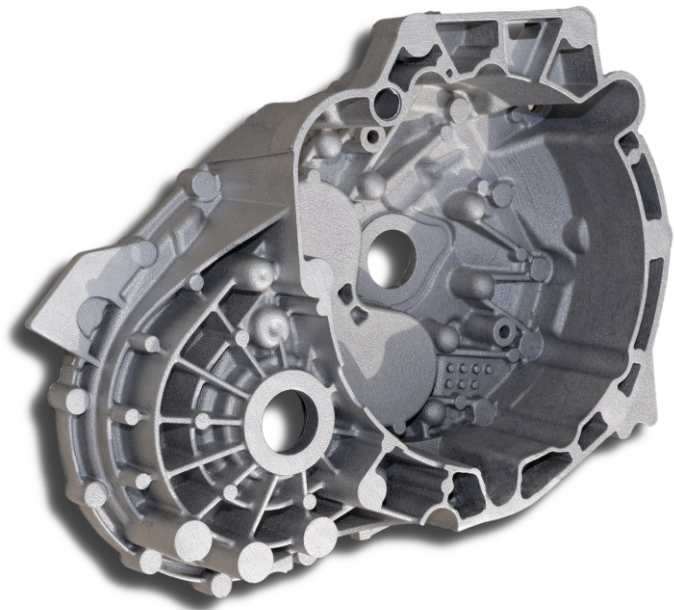

PHOTO GALLERY



Providing a complete service from design to functional end product



CONTACT INFO

Sales

✉ sales@procastsolutions.eu

 [PCS d.o.o](https://www.linkedin.com/company/PCS-d.o.o)

Jernej Homar

✉ jernej.homar@procastsolutions.eu

☎ + 386 31 574 716

Moreno Zuin

✉ moreno.zuin@procastsolutions.eu

☎ + 39 392 950 35 65

Matteo Poier

✉ sales@procastsolutions.eu

☎ + 39 347 825 55 06

